

1150K

**LT/WT/LGP
CRAWLER DOZER**

ENGINE

Model	Case Family IV 667TA/EDJ
Cylinders	6
Bore/Stroke	4.09 x 5.20 in (104 x 132 mm)
Displacement	409 in ³ (6.7 L)
Fuel injection	Direct
Fuel	#2 Diesel
Fuel filter	Primary spin-on with in-line strainer
Air intake	Cross-flow
Cooling	Liquid
Engine speeds (rpm)	
High idle - no load	2350±50
Rated - full load	2200
Low idle	900-1100
Horsepower per SAE J1349	
Net	118 (88 kW) @ 2200 rpm
Gross	130 (97 kW) @ 2200 rpm
Peak torque @ 1400 rpm	
Net	418 lb-ft (567 N·m)
Gross	434 lb-ft (589 N·m)
Engine lubrication -	
Pump	Deep sump plate cooler with pressurized under-piston nozzles
Pump operating angle ratings	
Side-to-side	45°
Fore and aft	45°

ENGINE COOLING

Radiator -	
Core size area	939 in ² (0.61 m ²)
Rows of tubes	4
Fan -	
Diameter	26.1 in (662 mm)
Ratio	0.9:1

ELECTRICAL SYSTEM

Alternator	65 amp
Voltage	24 volt system
Battery	
(2) 12-volt low-maintenance 700 cold-crank- ing amps @ 0° F (-18 C)	

POWERTRAIN

Dual path hydrostatic	
Pump - variable axial piston	
Motor - variable bent axis piston	
Maximum drawbar pull*	48,000 lb (213.5 kN)
Transmission	Single lever control - electronic straight tracking
Oil filter	2 micron, spin-on replaceable
Travel speeds* -	
Forward	0-6 mph (0-9.7 km/h)
Reverse	0-6 mph (0-9.7 km/h)
*Measured using standard track chain. Increase travel speeds by 4% and reduce drawbar pull by 4% with the optional CELT track chain.	
Parking brakes	Heavy-duty, spring-applied, hydraulic pressure release
Steering brakes	Hydrostatic
Final drive	2 helical gear reduction to planetary output
Ratio	61:1

TRANSMISSION COOLING

Type	Oil to air
Core size	844 in ² (54 452 cm ²)

HYDRAULIC SYSTEM

Standard equipment pump	
Pump flow @ 2200 rpm @ 2830 psi (195 kPa)	34.9 gpm (132 L/min)

CYLINDERS

Lift cylinder (2)	
Bore diameter	4.25 in (108 mm)
Rod diameter	2 in (50.8 mm)
Stroke	17.52 in (445 mm)
Angle cylinder (2)	
Bore diameter	5 in (127 mm)
Rod diameter	2.5 in (64 mm)
Stroke	15.0 in (381 mm)
Tilt cylinder (1)	
Bore diameter	5 in (127 mm)
Rod diameter	2.5 in (64 mm)
Stroke	4.72 in (120 mm)

UNDERCARRIAGE

Track adjustment	Hydraulic
Frame	Oscillating equalizer beam suspension and pivot shaft
Length of track on ground	102 in (2.59 m)
Track link pitch -	
CLT track	6.9 in (175 mm)
CELT track	6.9 in (175 mm)
Track shoe height	2.07 in (53 mm)
Pin diameter	1.44 in (37 mm)
Bushing diameter -	
CLT track	2.44 in (62 mm)
CELT track	3.1 in (79 mm)
Bolt diameter	0.625 in (16 mm)
Track shoes per side -	
CLT track	43
CELT track	43
Track rollers per side	7
Carrier rollers per side	2
Track roller rail dia.	7.5 in (190 mm)

AREA OF TRACK ON GROUND

Shoe	Area - in ² (cm ²)
20 in (508 mm)	4,800 (30 968)
24 in (610 mm)	4,896 (31 587)
30 in (762 mm)	6,120 (39 484)
34 in (864 mm)	6,936 (44 748)

TRACK AND SHOE OPTIONS

Extra Long Track	
20 in (508 mm) closed grousers and CLT	
20 in (508 mm) open grousers and CELT	
24 in (610 mm) closed grousers and CLT	
24 in (610 mm) open grousers and CELT	
Wide Track	
20 in (508 mm) closed grousers and CLT	
20 in (508 mm) open grousers and CELT	
24 in (610 mm) closed grousers and CLT	
24 in (610 mm) open grousers and CELT	
30 in (762 mm) closed grousers and CLT	
30 in (762 mm) open grousers and CELT	
Low ground pressure	
34 in (864 mm) closed grousers and CLT	
34 in (864 mm) open grousers and CELT	

OPERATOR ENVIRONMENT

ROPS canopy
Adjustable armrests
Foot rests
Retractable seat belt, 2 in (51 mm)
Vinyl suspension seat w/back adjustment
Headliner
Floormat
Mirror
Entire structure tilts for access

INSTRUMENTATION

Warning lights:

Air filter
Alternator
Diagnostic fault indicator
Engine coolant temperature
Engine oil pressure
Hydraulic filter
Low fuel level
Park brake engaged
Service soon indicator
Transmission filter
Transmission charge pressure

Gauges:

Battery voltage
Digital hourmeter/tachometer/diagnostic/service reminder
Fuel level
Transmission oil temperature
Transmission speed indicator
Water temperature

Audible warnings:

Engine coolant temperature
Engine oil pressure
Low fuel level
Transmission charge pressure
Transmission/hydraulic temperature

BLADE

Blade pitch (adjustable)	55°- 60°
Cutting edge	Reversible and replaceable
Width	8.0 in (203 mm)
Thickness	0.75 in (19 mm)

RIPPER

Max. penetration	19 in (483 mm)
Width	67.4 in (1711 mm)
Cut width	64.4 in (1635 mm)
Ground clearance (shanks in top position)	16.7 in (424 mm)
Points	Replaceable
Max. number of shanks	3
Tooth spacing – with 3 teeth	31 in (787 mm)
Hydraulic cylinder (double-acting)	
Diameter	4 in (102 mm)
Stroke	10 in (254 mm)
Rod	2 in (51 mm)

SERVICE CAPACITIES

Fuel tank	65 gal (246 L)
Engine oil w/filter	16.5 qt (15.6 L)
Engine oil w/o filter	17.3 qt (16.4 L)
Engine cooling system	34 qt (32 L)
Cooling system – Cab w/heater and AC	34.3 qt (32.5 L)
Hydraulic reservoir	26 gal (98.4 L)
Final drive (per side)	15 qt (14.2 L)
Track rollers (ea.)	0.48 qt (0.45 L)
Front idlers (ea.)	0.46 qt (0.49 L)
Carrier rollers (ea.)	0.31 qt (0.29 L)

OPERATING WEIGHTS

Unit equipped with ROPS, full fuel tank, 170 lb (77 kg) operator, side shield, track guides, backup alarm, horn, lights and rear retrieval hitch

Long Track	27,858 lb (12 636 kg)
Wide Track	28,667 lb (13 003 kg)
LGP	29,365 lb (13 317 kg)

Add-on weights –

Drawbar	146 lb (66 kg)
Ripper (3 shank)	2,300 lb (1043 kg)
Winch	2,100 lb (952 kg)
Front counterweight	1,091 lb (495 kg)
Cab	920 lb (417 kg)
ROPS heater	70 lb (32 kg)
CELT chain	375 lb (170 kg)

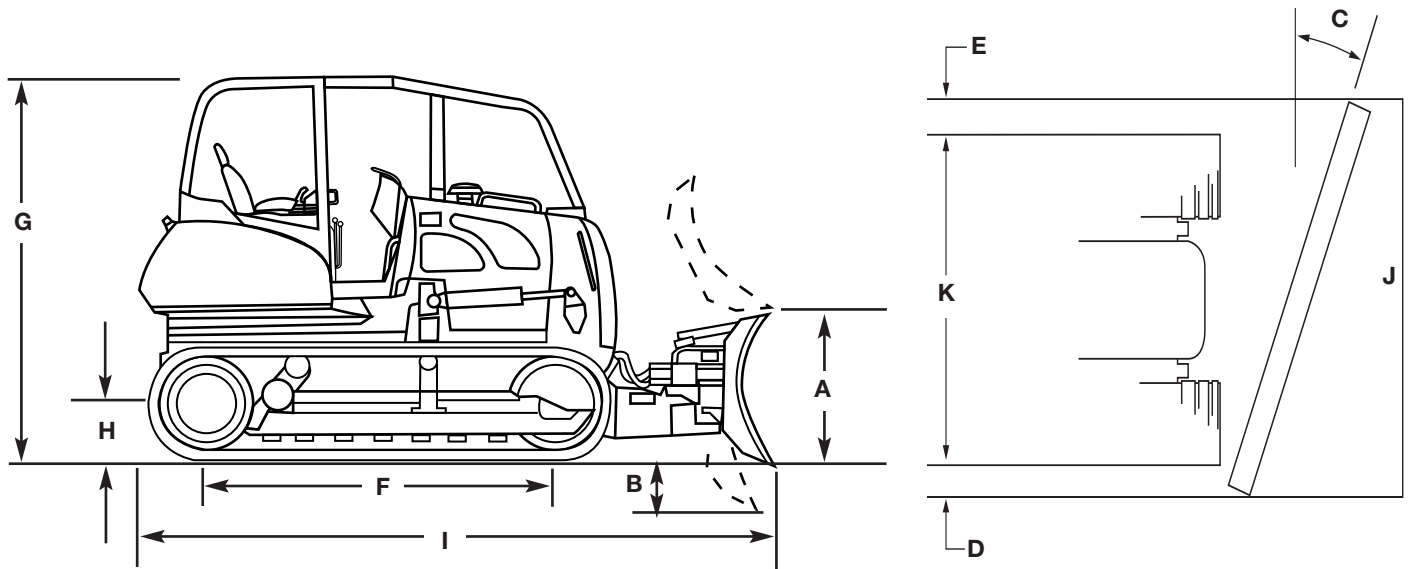

DIMENSIONS

	Extra Long Track (XLT)	Wide Track (WT)	Low Ground Pressure (LGP)
BLADES			
Blade width	120 in (3.05 m)	132 in (3.35 m)	132 in (3.35 m)
SAE blade capacity	3.8 yd ³ (2.9 m ³)	4.2 yd ³ (3.2 m ³)	4.2 yd ³ (3.2 m ³)
A. Blade lift above ground	38 in (965 mm)	38 in (965 mm)	38 in (965 mm)
B. Blade depth below ground	19 in (483 mm)	19 in (483 mm)	19 in (483 mm)
C. Blade angle both directions	25°	25°	17°
Blade tilt, each end (up to 8.3°)	17.3 in (439 mm)	19 in (483 mm)	19 in (483 mm)
Blade height	44 in (1118 mm)	44 in (1118 mm)	44 in (1118 mm)
D. Cast reach	15 in (381 mm)	14.2 in (361 mm)	11.2 in (284 mm)
E. Cut reach	-.2 in (-5 mm)	-.5 in (-13 mm)	-3.5 in (-89 mm)
TRACKS			
Track gauge	70 in (1.78 m)	78 in (1.98 m)	78 in (1.98 m)
Max shoe width	24 in (610 mm)	30 in (762 mm)	34 in (864 mm)
F. Track on ground	102 in (2.59 m)	102 in (2.59 m)	102 in (2.59 m)
Area of track on ground	4896 in ² (3.16 m ²)	6120 in ² (3.95 m ²)	6936 in ² (4.47 m ²)
Ground pressure	5.7 psi (39.7 kPa)	5.0 psi (34.5 kPa)	4.23 psi (29.2 kPa)
DIMENSIONS			
G. Height to top of ROPS	9 ft 4 in (2.83 m)	9 ft 4 in (2.83 m)	9 ft 4 in (2.83 m)
Height to top of cab	9 ft 4 in (2.83 m)	9 ft 4 in (2.83 m)	9 ft 4 in (2.83 m)
H. Ground clearance w/drawbar	14.9 in (379 mm)	14.9 in (379 mm)	14.9 in (379 mm)
Length –			
I. Blade straight with drawbar	16 ft 6 in (5.03 m)	16 ft 6 in (5.03 m)	16 ft 6 in (5.03 m)
Blade straight with ripper	19 ft 7 in (5.97 m)	19 ft 7 in (5.97 m)	19 ft 7 in (5.97 m)
Width –			
Blade straight	10 ft (3.05 m)	11 ft (3.35 m)	11 ft (3.35 m)
J. Blade angled	9 ft 3 in (2.82 m)	10 ft 2 in (3.10 m)	10 ft 2 in (3.10 m)
K. Over track	94 in (2.39 m)	106 in (2.69 m)	112 in (2.84 m)

NOTE: Ground clearance and overall height dimensions are with the grousers fully penetrated. Add 52.5 mm (2.07 in) if unit is on solid surface.

STANDARD EQUIPMENT

OPERATOR'S COMPARTMENT

ROPS/FOPS canopy
Vinyl suspension seat w/back adjustment
Retractable seat belt, 2 in (51 mm)
Adjustable armrests
Foot rests
Tool storage area
Headliner
Floor mat
Entire structure tilts for access

ENGINE

Case Family IV 667TA/EDJ
Automatic fan belt tensioner
Integral engine oil cooling
Fuel filter
Dual element radial seal air cleaner
65 amp alternator
(2) 700 CCA 12-volt batteries
Anti-sandblast radiator
Engine side panels

OPTIONAL EQUIPMENT

OPERATOR'S COMPARTMENT

Cab (w/heater, defroster, A/C, front windshield washer and lights)
ROPS heater
3 in (76 mm) seat belt
Deluxe air suspension seat

HYDRAULICS

4 spool hydraulic valve for field-installed ripper

REAR MOUNTED EQUIPMENT

Ripper, 3 slot with 3 shanks

POWERTRAIN

Dual path infinitely variable, single-lever controlled hydrostatic drive with electronic straight tracking & counter-rotation, 4-position forward/reverse ratio control
Final drive – Triple reduction – helical gear/planetary decelerator with hydrostatic drive retardation
Automatic spring applied parking brake

BLADE

55° - 60° variable pitch with integral adjustment tool
Single lever electro hydraulic control for blade lift, angle and tilt

UNDERCARRIAGE

Hydraulic track adjusters
Case Lubricated Track Chain
Permanently lubricated track and carrier rollers and idlers
Track adjuster guard
Track guides (front and rear)

OTHER

Backup alarm
Horn
Anti-vandalism package
Mirror
Pre-cleaner
Lights - 2 front, 1 rear
Rear transmission guard
Front pull hook

BLADES

120 in (3.05 m) XLT w/24 in (610 mm) shoes
132 in (3.35 m) WT w/30 in (762 mm) shoes
132 in (3.35 m) LGP w/34 in (864 mm) shoes

GUARDS

ROPS canopy brush guard
CAB canopy brush guard
Center rockguard

SCREENS

Rear ROPS and cab
Side ROPS
Radiator brush

OTHER

Counterweight, front
Drawbar, short
Drawbar, long
Rear retrieval hitch
Environmental drains
Turbine precleaner
Rear wiper for cab
Tool box for ROPS
PTO equipment pump for winch drive
Special paint
Case Extended Life Track
Grid heater
Additional lights (2 front, 1 rear)

NOTE: All specifications are stated in accordance with SAE Standards or Recommended Practices, where applicable.

NOTE: All engines meet current EPA emissions requirements.

IMPORTANT: CNH America LLC reserves the right to change these specifications without notice and without incurring any obligation relating to such change. CNH America LLC does not warrant the safety or reliability of attachments from other manufacturers.

Case is a registered trademark of CNH America LLC. Any trademarks referred to herein, in association with goods and/or services of companies other than CNH America LLC, are the property of those respective companies.



www.casece.com